

Technical Information Bulletin

Installing Remote Door Unlock S3000 and S3000i

SYSTIB-02

S3000 input/output circuitry has been designed to interface with the trigger line (low current) for a vehicle's remote door unlock circuit. In some cases, it may be difficult for an installer to identify or find the door unlock trigger line, and an interface may be attempted with the remote door unlock solenoid (high current) circuit instead.

Connecting the S3000 directly to any high current solenoid circuit can overload the S3000 circuitry and cause the unit to fail. Instead, an external automotive relay should be used to safely isolate the S3000 from the solenoid circuit high current. This Technical Information Bulletin describes how to correctly use an external relay with the S3000 for remote door unlock applications.

For maximum reliability, we recommend using an external relay for all remote door unlock applications.

When integrating the remote door unlock feature on a vehicle, a 'normally open' relay will have to be wired in series with the door unlock line on the tracker. This relay will create the needed protection of the devices input and output circuitry and will eliminate the possibility of damage to the device's I/O circuitry.

See below diagram for correct relay configuration and integration:

Vehicles requiring Positive Trigger

Remote Door Unlock Wiring Diagram

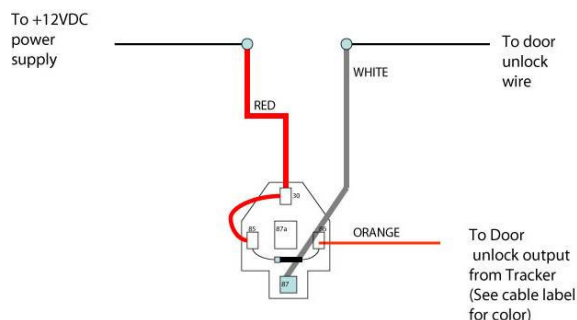

Vehicles requiring Negative Trigger

Remote Door Unlock Wiring Diagram

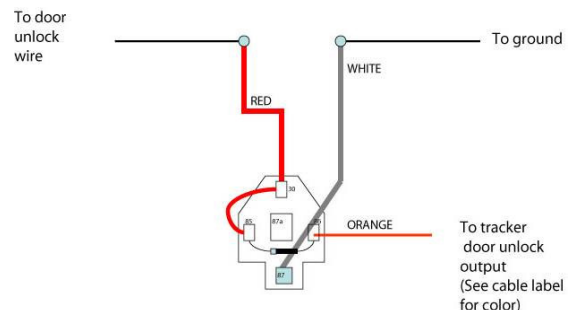

The information contained in this TIB is considered confidential and protected as such under contractual agreements between SysLocate and its reseller network.